

The screenshot displays the ARXivar software interface. On the left, there is a sidebar with a 'Search results' section containing a table of documents. The main area is divided into two panes: a workflow diagram on the right and a document preview on the left. The workflow diagram shows a process starting with 'Start', followed by 'Process', 'Rec-maint registration', 'Check', 'Approve', 'Evaluate the payment', and 'Payment'. The document preview shows a Gartner report titled 'Magic Quadrant for Suites'.

Document	Unit	System ID	Version	From	To	Document date	Document type
DEMO	52	0		ECONGAS	ABLE TECH SRL	14/04/2009	ACC.FATTIV
Selected document	DEMO	51	0	Accorade S.p.A.	ABLE TECH SRL	14/04/2009	SALES-QUOTRQ
Open	DEMO	50	0	ABLE TECH SRL	ABLE TECH SRL	14/04/2009	SALES-SUDDOC
Profile	DEMO	49	1	DEMO/Adnan	ERGOSEK	14/04/2009	ACC-ACCDOC
Log	DEMO	48	0	FUJITSU EUROPE LIMITED (M...	ABLE TECH SRL	14/04/2009	ACC-ACCDOC
Delete document	DEMO	47	0	FUJITSU EUROPE LIMITED (M...	ABLE TECH SRL	14/04/2009	ACC-ACCDOC
Memo list	DEMO	46	0				
Attachment list	DEMO	45	0				
Export	DEMO	44	0				
Print	DEMO	43	2				
Print	DEMO	42	0				
Workflow	DEMO	41	0				
Digital sign	DEMO	40	0				
Paperless archive	DEMO	39	0				
Other operat.	DEMO	38	0				
	DEMO	37	0				
	DEMO	36	0				
	DEMO	35	2				
	DEMO	34	0				
	DEMO	33	0				

PRESENTAZIONE di ARXivar

Murphy law

“Le possibilità di ritrovare un’informazione archiviata sono inversamente proporzionali alla sua importanza”



“Noi non ne abbiamo bisogno”

ma ...

- Il 20% del tempo degli impiegati è usato per gestire i documenti
- Il 40% dei doc. viene copiato 3/4 volte
- Il 7% dei doc. non si trova più
- Il 20% doc. non sono disponibili quando servono
- L'80% doc. archiviati non vengono mai utilizzati. Di questi, la maggior parte dell'azienda ne ignora l'esistenza e quindi vengono ricreati
- Per ogni fax inviato perdiamo 7 minuti i tempo

Allora forse

- La gestione dei documenti e delle informazioni è un **problema**
- Il costo della loro gestione si avvicina all'1% del vostro fatturato?
- Non basta archiviare i documenti bisogna **gestirli**
- **La loro gestione ci porta a migliorare l'efficienza e a risparmiare**

Si ma come?

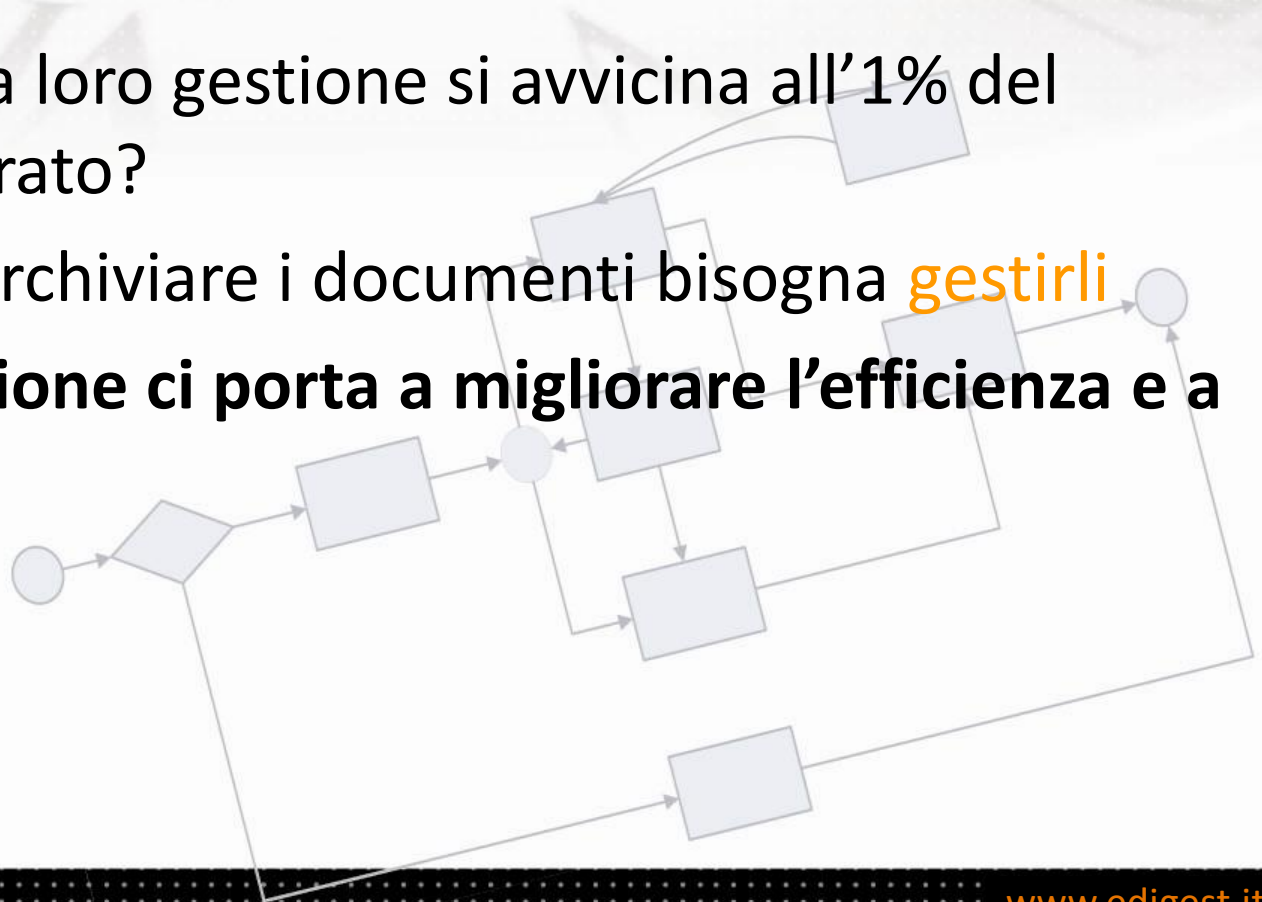

Pochi e semplici accorgimenti

- Centralizzare le informazioni
- Migliorare la sicurezza
- Backup e aggiornamenti
- Semplificare l'organizzazione
- Facilitare la ricerca
- Condividere le informazioni
- Integrazione Documenti, Mail , Fax
- Integrazione con il sistema gestionale.
- Organizzare i lavori gestendo i processi
- **Essere autonomi nella loro gestione**



The screenshot displays the ARXivar software interface. On the left, a sidebar contains various document management actions such as 'Open', 'Profile', 'Log', 'Delete document', 'Memo list', 'Export', 'Print', 'Version', 'Organize', 'Distribute', 'Barcode', 'Digital sign', and 'Paperless archive'. The main window is divided into several sections:

- Workflow Diagram:** A central flowchart showing a process starting with 'Start', followed by 'Receivable registration', 'Check', 'Approve', 'Check payment', and 'Invoice payment'. There are also 'Refuse' and 'Reedit' paths.
- Table:** A table with columns: Unit, System ID, Version, From, To, Document date, Document type. It lists various document entries with their respective IDs and dates.
- Document Preview:** A preview of a document titled 'Gartner Magic Quadrant for Suites' with a publication date of 18 February. The text below the title reads: 'Jensile B. Hill, Michele Cantorio, Gartner has revised its BPM for the use case, culture, flow'.

COS'E' ARXivar

C'erano una volta ...

SISTEMI DI ARCHIVIAZIONE DOCUMENTALE

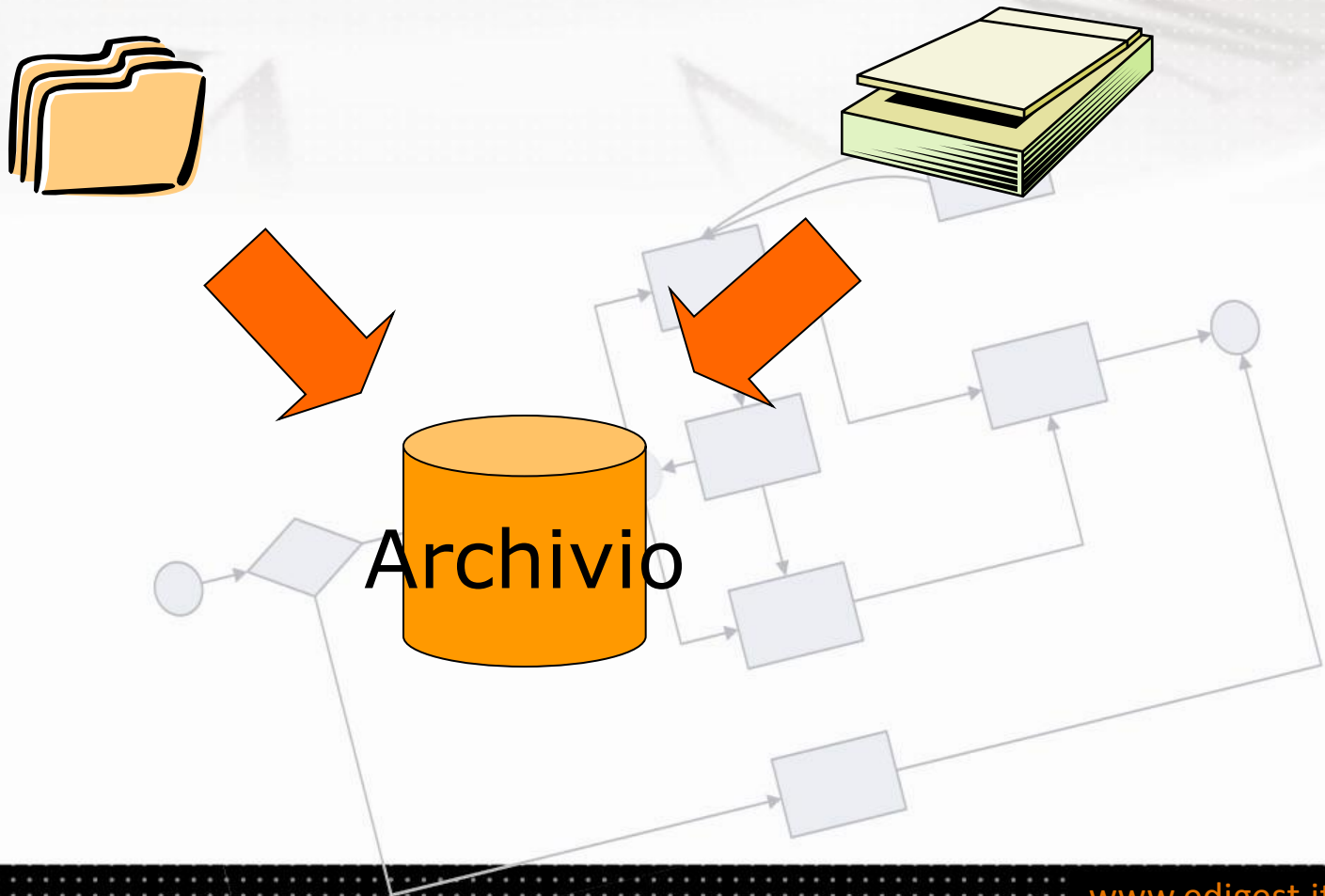

Oggi non basta più archiviare



Dobbiamo integrare

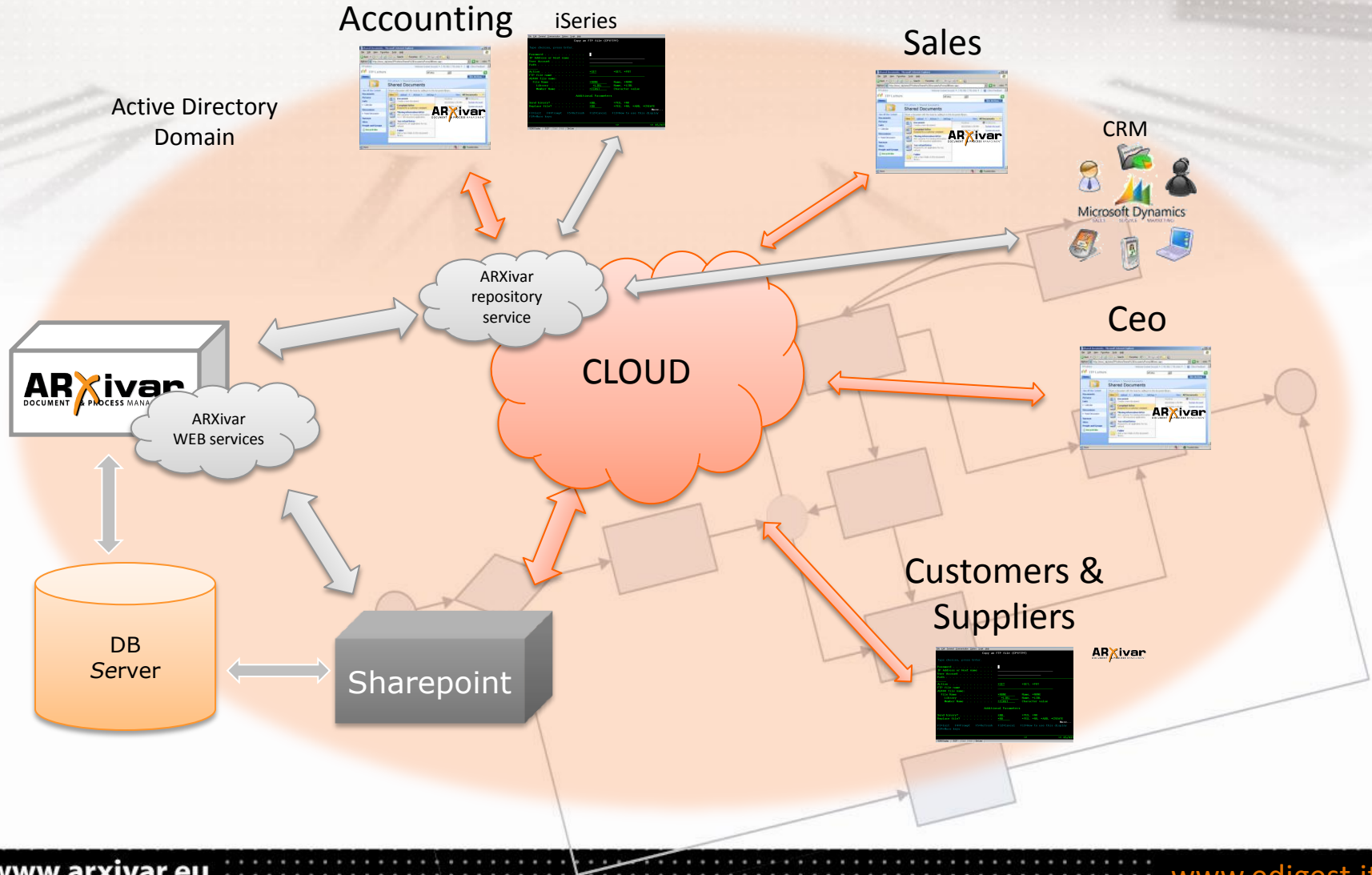

E gestire le informazioni

ARXivar[®]
DOCUMENT & PROCESS MANAGEMENT

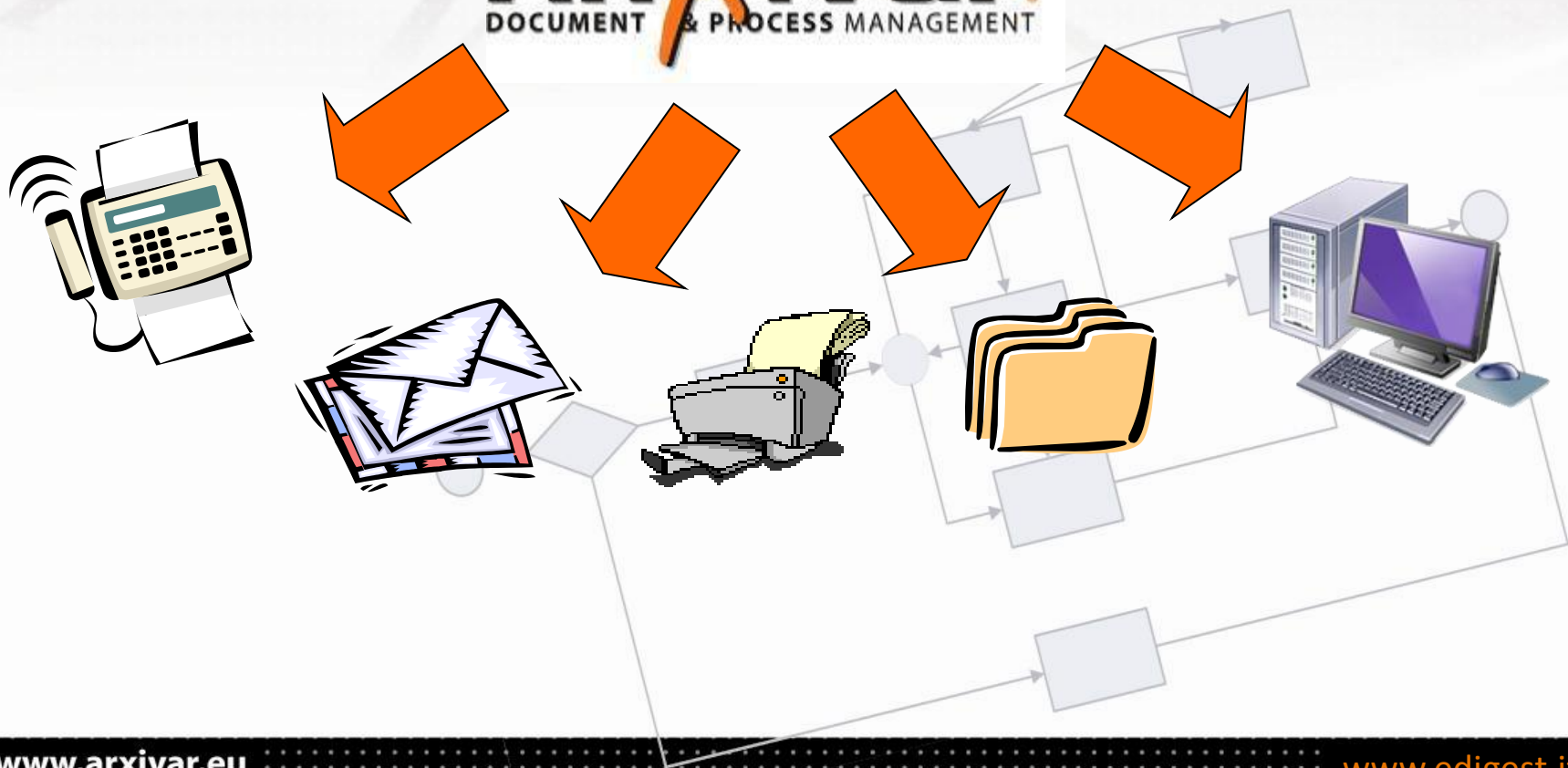

Workflow & BPM

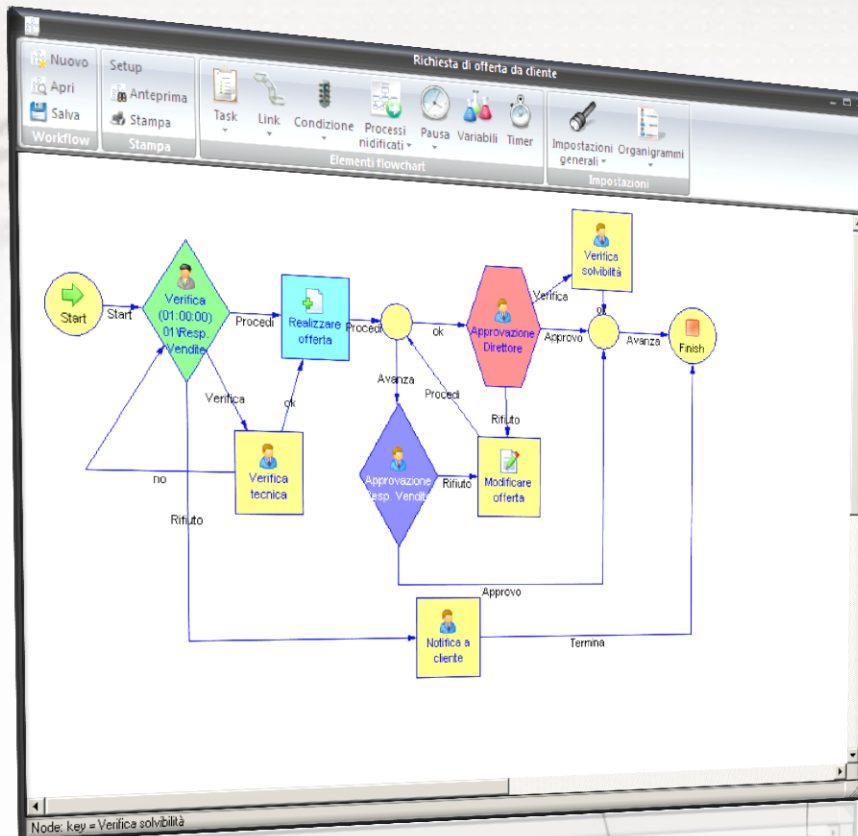

Task: Realizzare offerta

Concludi task Esci

Dettagli

Dettaglio task

Realizzare offerta in base alle annotazioni del resp. vendite

Info task

Codice: 327
 Nome: Realizzare offerta
 Esecutori: 01|Admin
 Data inizio: 16/03/2009 22.49.21
 data fine: 17/03/2009 18.00.00

Info workflow

Nome: Richiesta di offerta da cliente
 Dettaglio: Gestione del processo di richiesta di offerta ed emissione della offerta a cliente
 Descrizione: Richiesta offerta da cliente Marco Simola del 30/12/2008

ALL IN ONE



The screenshot displays the ARXivar software interface. On the left, a sidebar contains a 'Commands' menu with options like 'Open', 'Profile', 'Log', 'Delete document', 'Memo list', 'Attachment list', 'Export', 'Print', 'Version', 'Version list', 'Service', 'Organize', 'Distribution', 'Full text', 'Barcode', 'Workflow', 'Digital sign', 'Paperless archive', and 'Others operat.'. The main area is divided into three sections: a table of documents, a workflow diagram, and a document preview.

Document	Unit	System ID	Version	From	To	Document date	Document type
DEMO	52	0		ECONGAS	ABLE TECH SRL	14/04/2009	ACC.PAYINV
DEMO	51	0		Aviorade S.p.A	ABLE TECH SRL	14/04/2009	SALES.QUOTE
DEMO	50	0		ABLE TECH SRL	ABLE TECH SRL	14/04/2009	SALES.SLIDOC
DEMO	49	1		DEMO/Admin	ERGOSTEX	14/04/2009	ACC.ACCDOC
DEMO	48	0		FUJITSU EUROPE LIMITED (P...	ABLE TECH SRL	14/04/2009	ACC.ACCDOC
DEMO	47	0		FUJITSU EUROPE LIMITED (P...	ABLE TECH SRL	14/04/2009	ACC.ACCDOC
DEMO	46	0					
DEMO	45	0					
DEMO	44	0					
DEMO	43	2					
DEMO	42	0					
DEMO	41	0					
DEMO	40	0					
DEMO	39	0					
DEMO	38	0					
DEMO	37	0					
DEMO	36	0					
DEMO	35	2					
DEMO	34	0					
DEMO	33	0					

The workflow diagram shows a process starting with 'Start' leading to 'Receivable registration', then to 'Dist mgr knowledge'. From 'Dist mgr knowledge', there are two paths: one through 'Check' to 'Check' and another through 'Approve' to 'Approve'. The 'Approve' step leads to a decision diamond with 'Yes' and 'No' paths. The 'No' path leads to 'CDO approval', which then leads to 'Invoice payment'. The 'Yes' path leads to 'Invoice payment'. There is also a 'Refuse' path from the decision diamond leading to 'CDO approval'. A 'Reed' path from the 'Check' step leads to 'Reed', which then leads to 'Reed'.

The document preview shows a Gartner publication titled 'Magic Quadrant for Suites' with a publication date of 18 February. The author is listed as Jennifer B. Hill, Michele Cantorio, and the text mentions that Gartner has revised its BPM for the 100 most visible global firms.

STRUTTURA di ARXivar

Repository

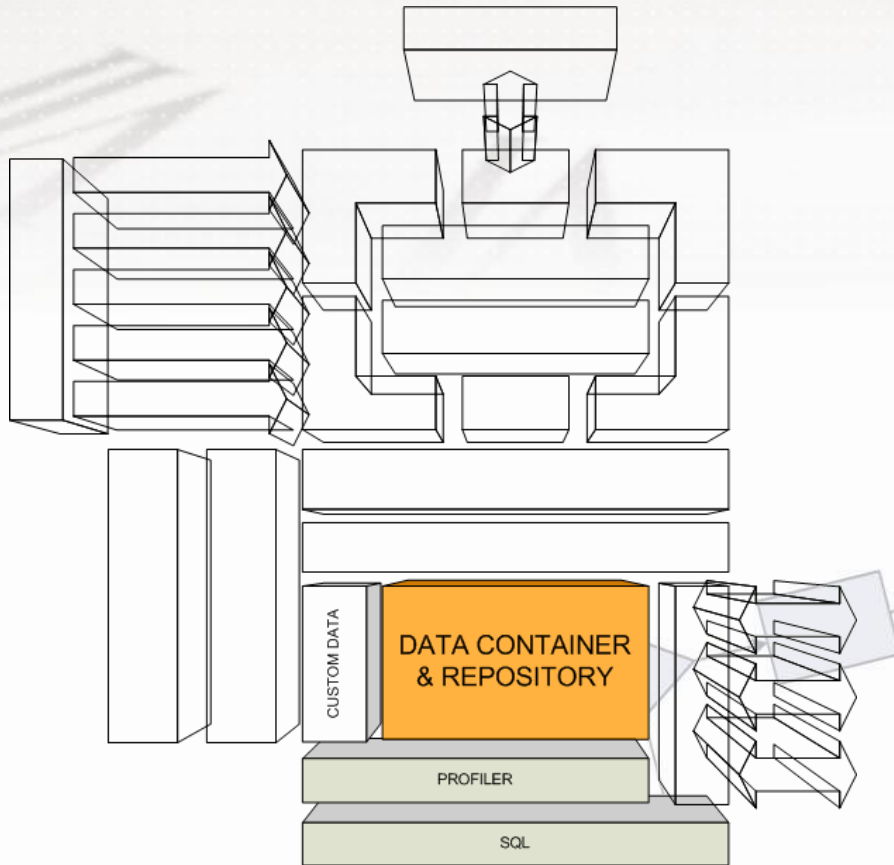

- SQL based
 - MS SQL
 - ORACLE
 - MySql
- Informazioni fisiche salvate nel database o nel file system
- Repository globale con localizzazione per area organizzativa omogenea

Struttura dei dati

Ogni documento archiviato viene separato in:

- **PARTE LOGICA**
 - Profilo documento
 - Archiviato nel DB
- **PARTE FISICA**
 - File compresso
 - File system
 - Database

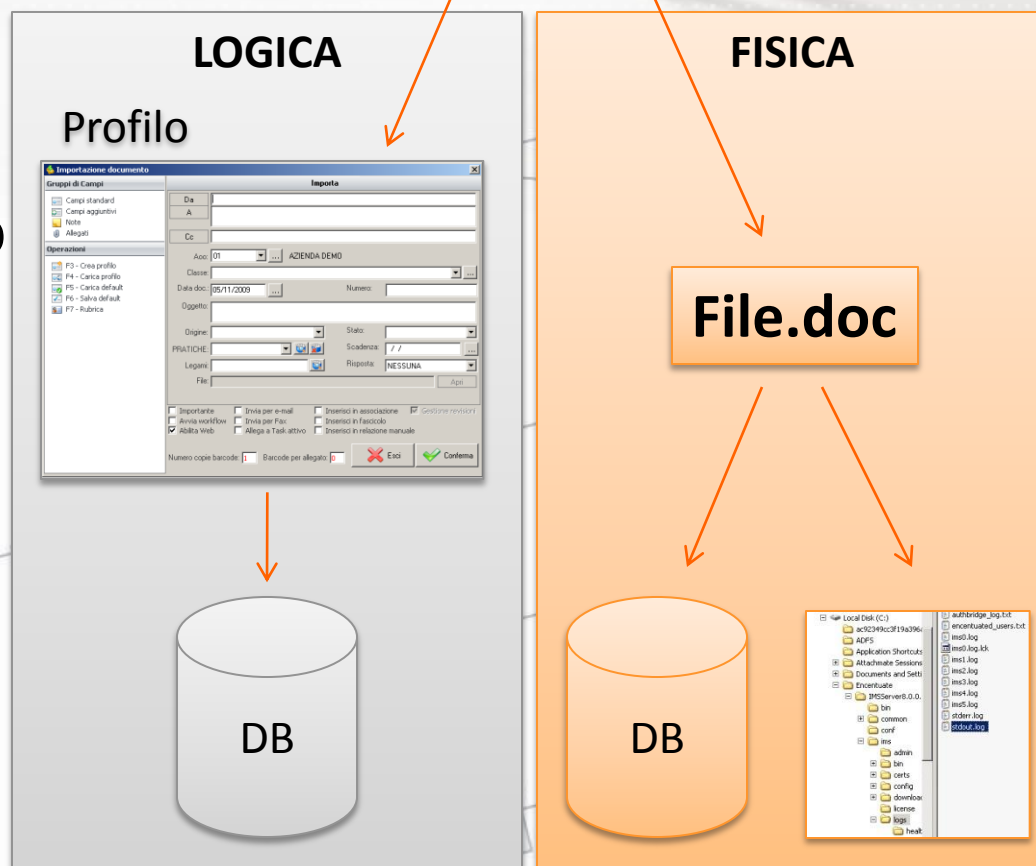

Are Organizzative Omogenee

- Possiamo separare la **parte fisica** in unità di archiviazione omogenee e per ognuna di queste definire dove devono essere salvati i dati
- Riduzione del traffico di rete

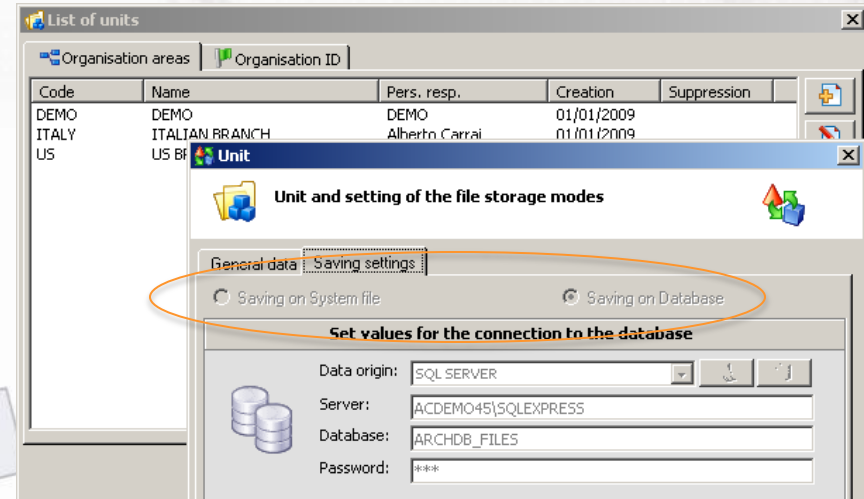

Sicurezza

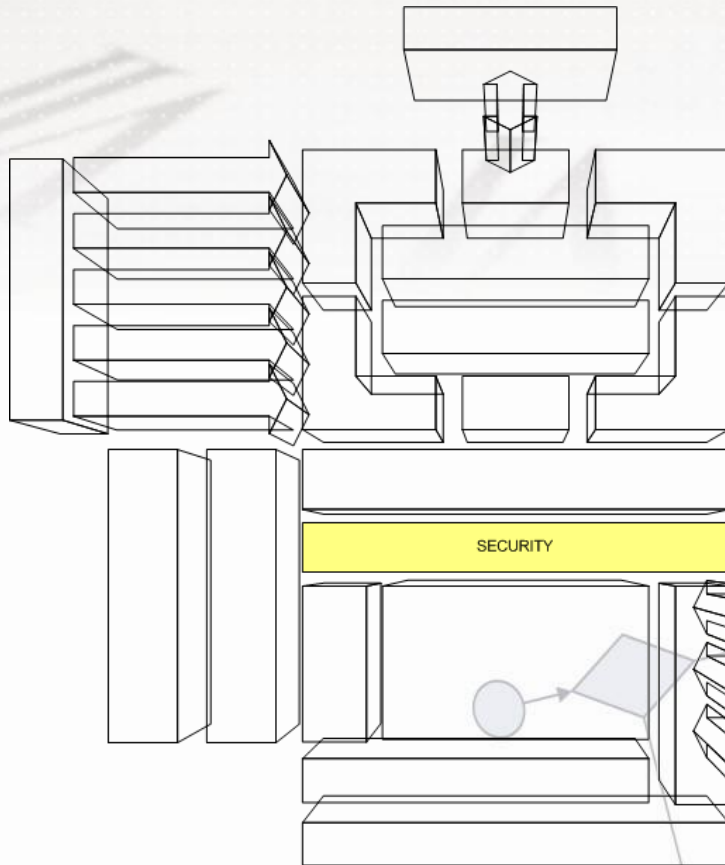

- Sicurezza fisica
 - Dati non visibili se non attraverso ARXivar client
 - Criptazione
- Sicurezza logica
 - Basata sui gruppi
 - Facile da gestire



Connettori

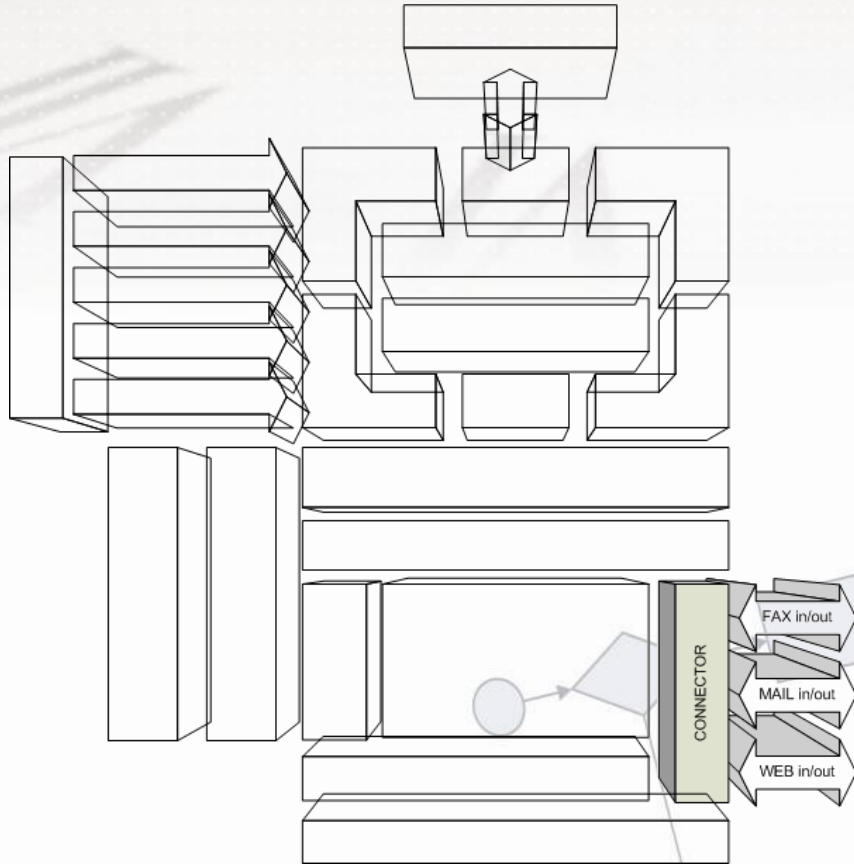

- Connettori verso i principali “produttori” di informazioni:

- ERP
- Mail
- Fax
- WEB
- SDK per connetere qualunque altra applicazione

INTEGRAZIONE MAIL

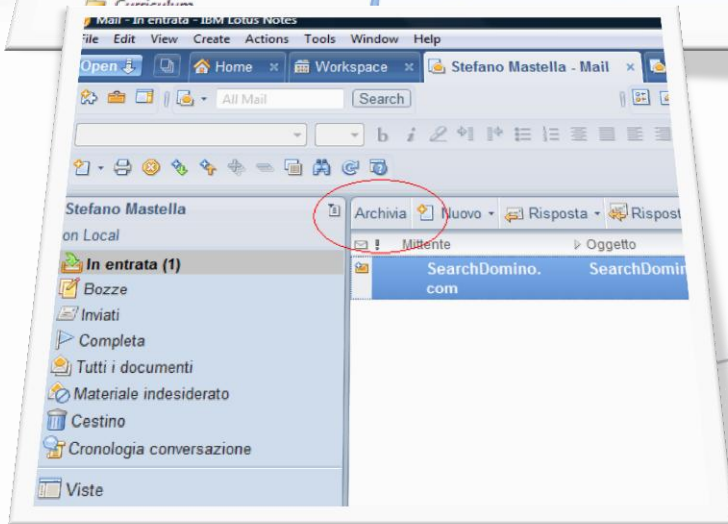
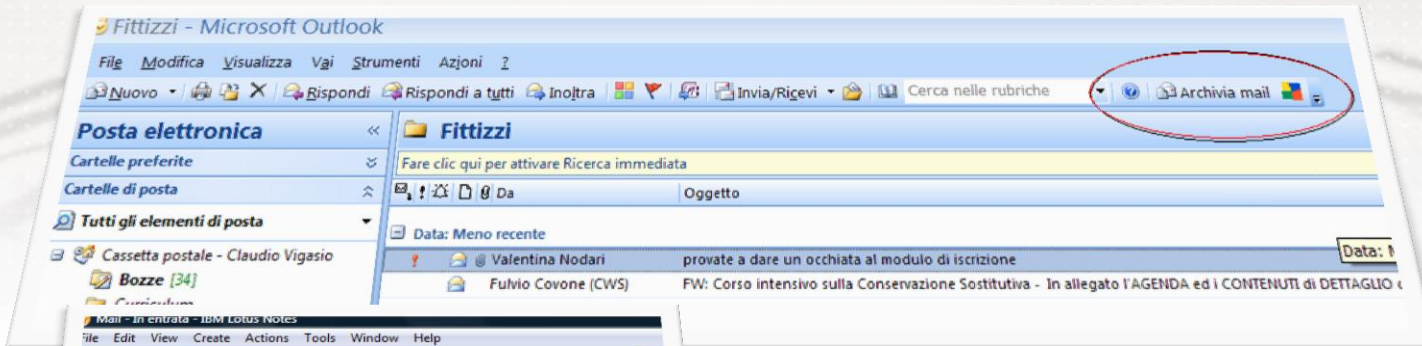

- ARCHIVIAZIONE MAIL MANUALE o AUTOMATICA
- Da Outlook, Exchange o Lotus Notes e POP3

INTEGRAZIONE MICROSOFT CRM

The screenshot shows a web browser window titled "Account: SNJ Media Studio s.r.l. - Windows Internet Explorer". The page displays the "Informazioni" (Information) section for an account. The left sidebar contains several categories: "Dettagli:" (with sub-items like Informazioni, Altri indirizzi, etc.), "Vendite:" (Opportunità, Offerte, etc.), "Servizi:" (Casi, Contratti), and "Marketing:" (Elenchi marketing, Campagne). The main content area has tabs for "Generale", "Dettagli", "Amministrazione", and "Note". The "Dettagli" tab is active, showing fields for account name, number, primary account, primary contact, relationship type, and currency (set to "euro"). Below this is the "Indirizzo" section with fields for address name, street (Via 1, Via 2, Via 3), city, province, CAP, country, phone, address type, shipping method, and shipping conditions. A red arrow points from the "Documenti Allegati" link in the sidebar to the "Indirizzo" section.

Integrazione ERP

```
File Edit Terminal Communication Options Script Help
Copy an FTP file (CPYFTPF)

Type choices, press Enter.

Password . . . . .
IP Address or Host name
User Account . . . . .
Path . . . . .

Action . . . . . *GET *GET, *PUT
FTP file name
AS400 file name:
File Name . . . . . *NONE Name, *NONE
Library . . . . . *LIBL Name, *LIBL
```

AS/400

Send Repla
F3=Ex
F24=h
5250 Dis

Dynamics NAV

Entrata merci Parametizzazione Sistema Help

Entrata merci Ordine d'acquisto 22567 - Giuseppe Fortunato

Riepilogo attivo | Parcheggiare | Controllare | Registrare | Help

Entrata merci | Ordine d'acquisto | Divisione ZN01 | EM per ORDACQ 101

Generale | Fornitore

Data documento 16.07.2008 Bolla cons. 000171 Fornitore FISSOEMOBILE PUBBLICITA
 Data di reg. 17.07.2008 Lettera vettura Tst. test.
 Bolla singola N. bolla acc.

Riga	Testo breve mat.	OK	Qtà in UMA	U.	Mag.	Carta	Div.	D	Tiplo stock	Div.
1	POSTER CARTA OPACA 170 GR F.TO A5 O	<input checked="" type="checkbox"/>	14		PZ Mag. isorella 1		101		Controllo q...	Flex S.P.A.
2	POSTER CARTA OPACA 170 GR F.TO A5 O	<input checked="" type="checkbox"/>	7		PZ Mag. isorella 1		101		Controllo q...	Flex S.P.A.
3	POSTER CARTA OPACA 170 GR F.TO A5 O	<input checked="" type="checkbox"/>	5		PZ Mag. isorella 1		101		Controllo q...	Flex S.P.A.
4	POSTER CARTA OPACA 170 GR F.TO A5 O	<input checked="" type="checkbox"/>	7		PZ Mag. isorella 1		101		Controllo q...	Flex S.P.A.
5	POSTER CARTA OPACA 170 GR F.TO A5 O	<input checked="" type="checkbox"/>	4		PZ Mag. isorella 1		101		Controllo q...	Flex S.P.A.

ad hoc ENTERPRISE Rel. 5.0 | Francesco Pasquini per INFODATI | Administrator | Az: MGR | Es: 2004

Archivi | Generale | Analitica | Tesoreria | Magazzino/Service | Vendite | Acquisti | Produzione | Moduli | Sistema | Utility ?

SAP

INFO READER

Periodo n° 1 - 01 gennaio 2004 - 31 sabato dicembre 2005

InfoReader ad hoc ENTERPRISE

Ultimo aggiornamento: 20/05/2005 16.53.13

Misure | Mese Generico | Settimana Generica | Settimana Specifica | Mese Specifico | Centro di Costo | Voce

		*Azienda		Totali	
		MAGRIS SPA			
Anno Specifico	Centro di Costo Aziendale	Voce Aziendale	<1> Budget	<1> Consuntivo	<1> Impegno
-2004	BIESSE PRODOTTI		0,00	-10,00	0,00
	VENDITE ARTICOLI CHIDE		400,00	-379,13	0,00
	VENDITE ARTICOLI KIMBERLY		-300,00	-321,32	0,00
	VENDITE CARTA CARIND		-45,00	-51,98	0,00
	VENDITE CARTA FORNITORE VARIE		-70,00	-64,62	0,00
	VENDITE MATERIALI		900,00	85,12	0,00
	VENDITE PASTICA MONDADO		30,00	34,89	0,00
	VENDITE PRODOTTI CAUL		-110,00	-103,52	0,00
	VENDITE PRODOTTI CARAB		-50,00	-43,94	0,00
	VENDITE PRODOTTI HENKEL		0,00	-6,48	0,00
	VENDITE PRODOTTI VARI		-50,00	-43,94	0,00
	VENDITE SCOPE - SPAZZOLE		0,00	-6,48	0,00
	Totale		-3.575,00	-4.011,21	0,00
Totale			-3.575,00	-4.011,21	0,00

ad hoc ENTERPRISE R... | Documento1 - Microsof... | 17.07

AdHoc Zucchetti

MS Sharepoint

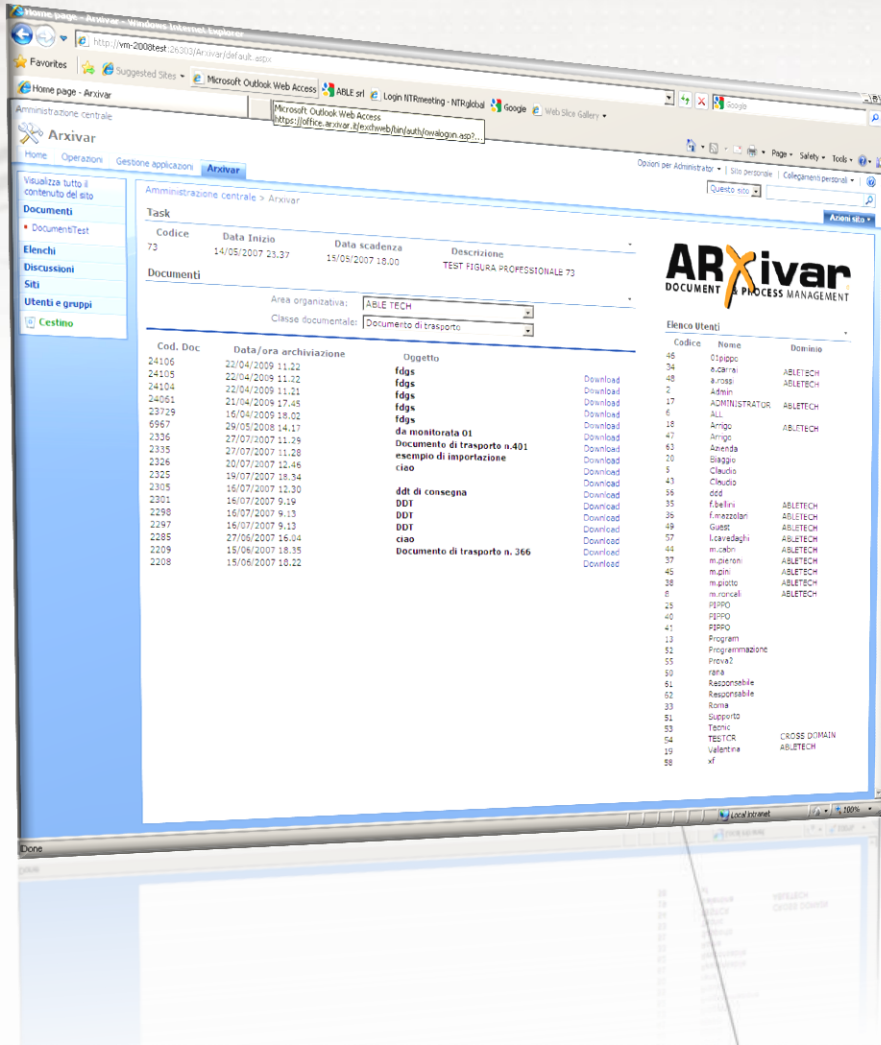

- Navigare i documenti di ARXivar direttamente da Sharepoint
- Avanzamento dei processi
- Distribuire i documenti dell'ERP

Workflow management

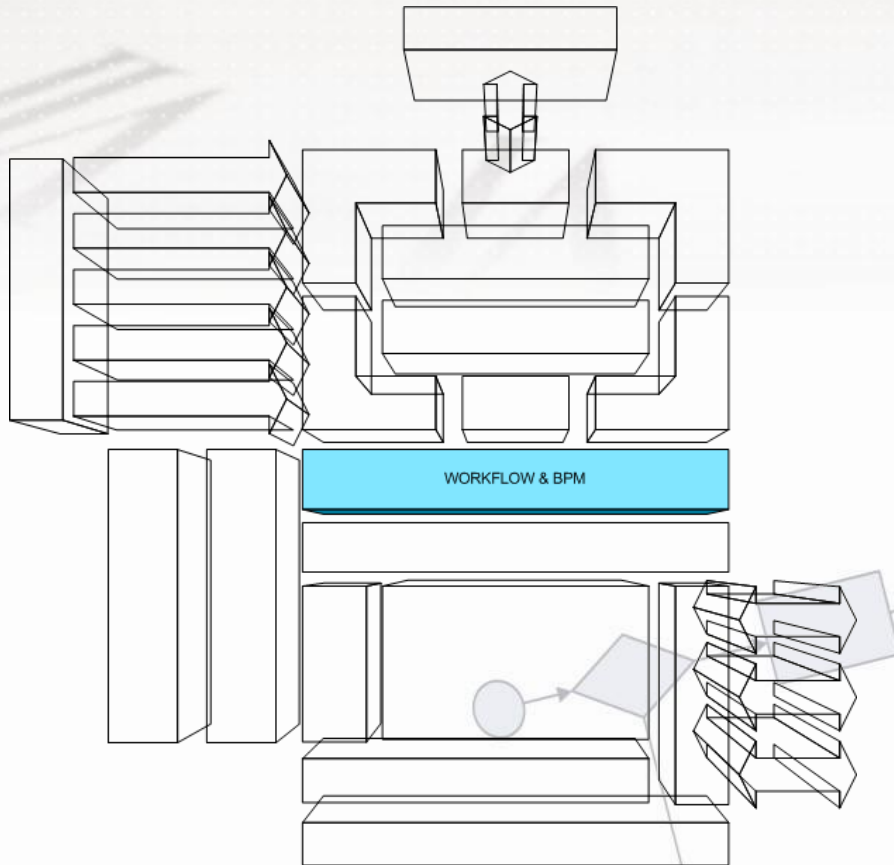

- Trasforma i vostri documenti in elementi attivi della vostra azienda
- Business Process Management
- Company Performance Management



Interfaccia

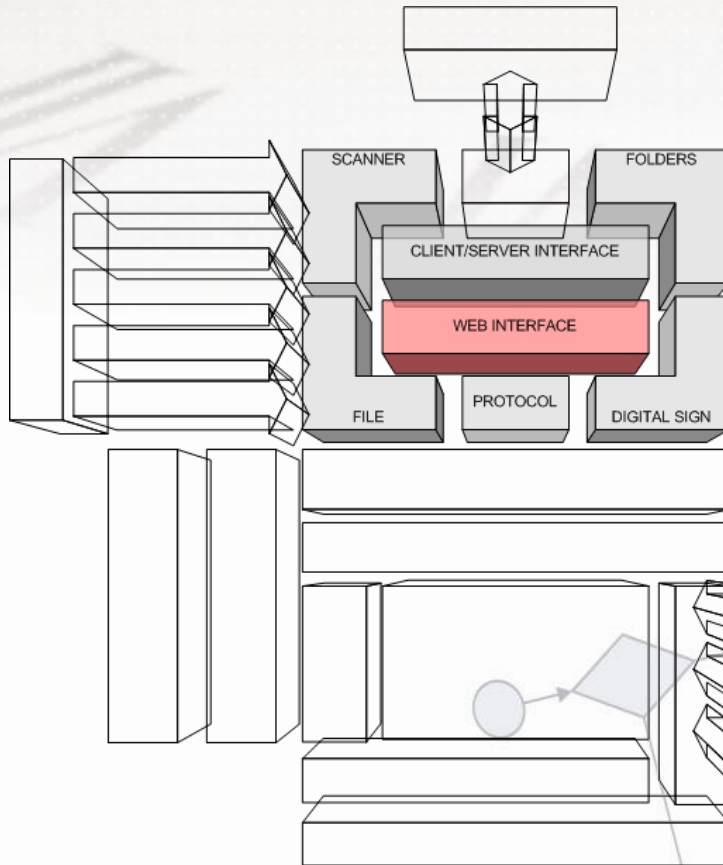

- Standard client/server
- Web client

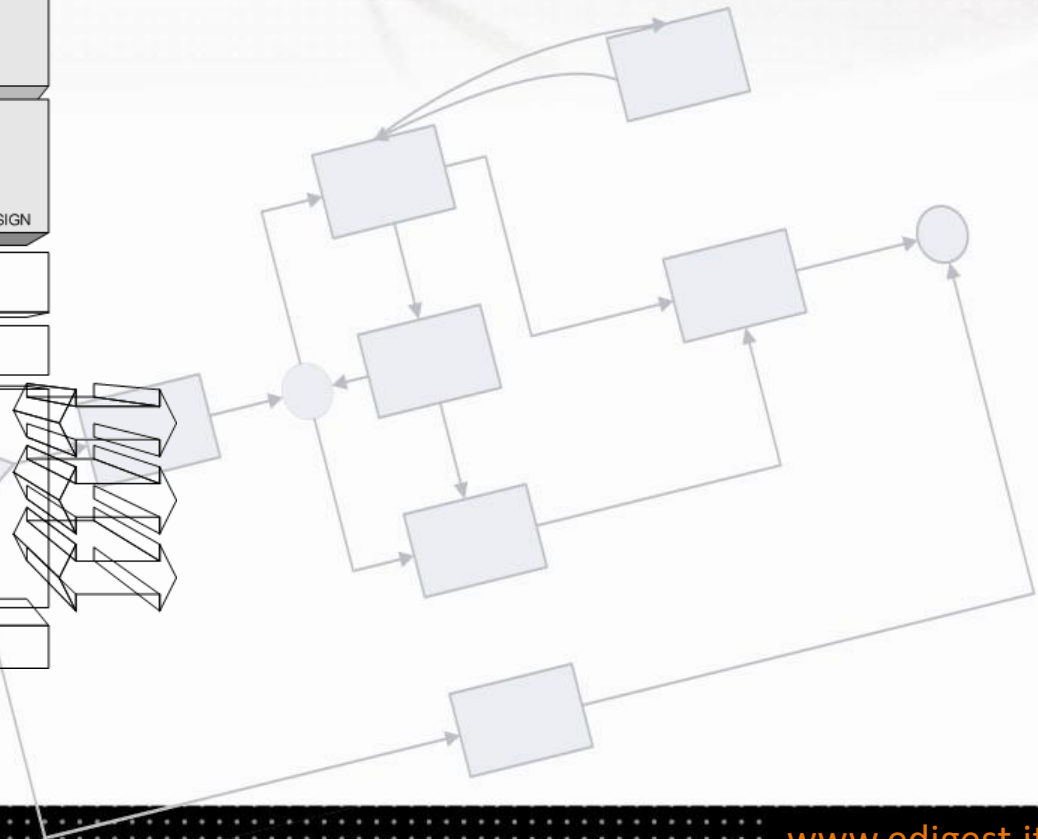

Template

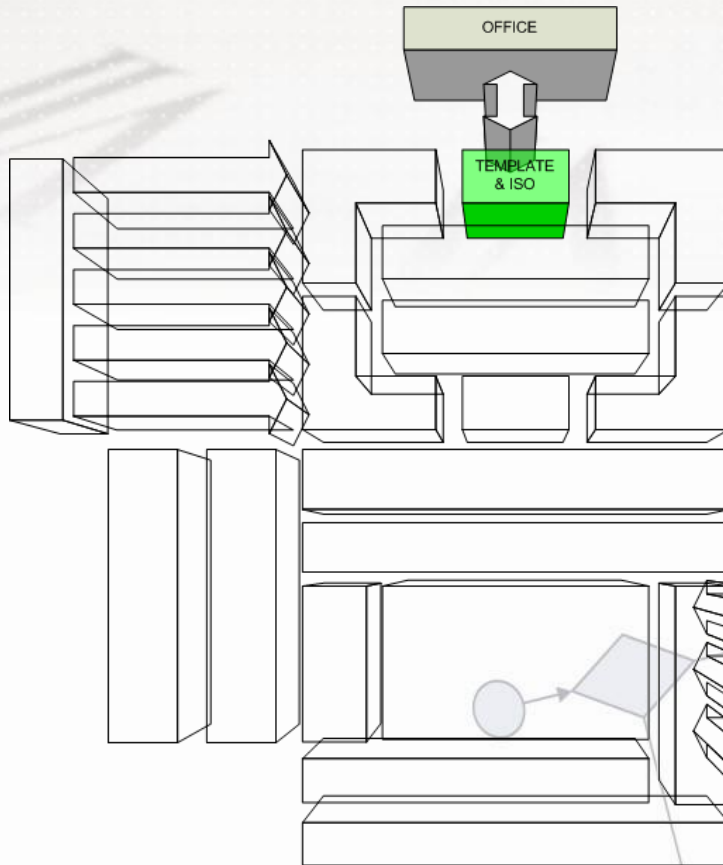

- ARXivar come punto di partenza per la creazione dei documenti
- Word, Excel
- Web Forms

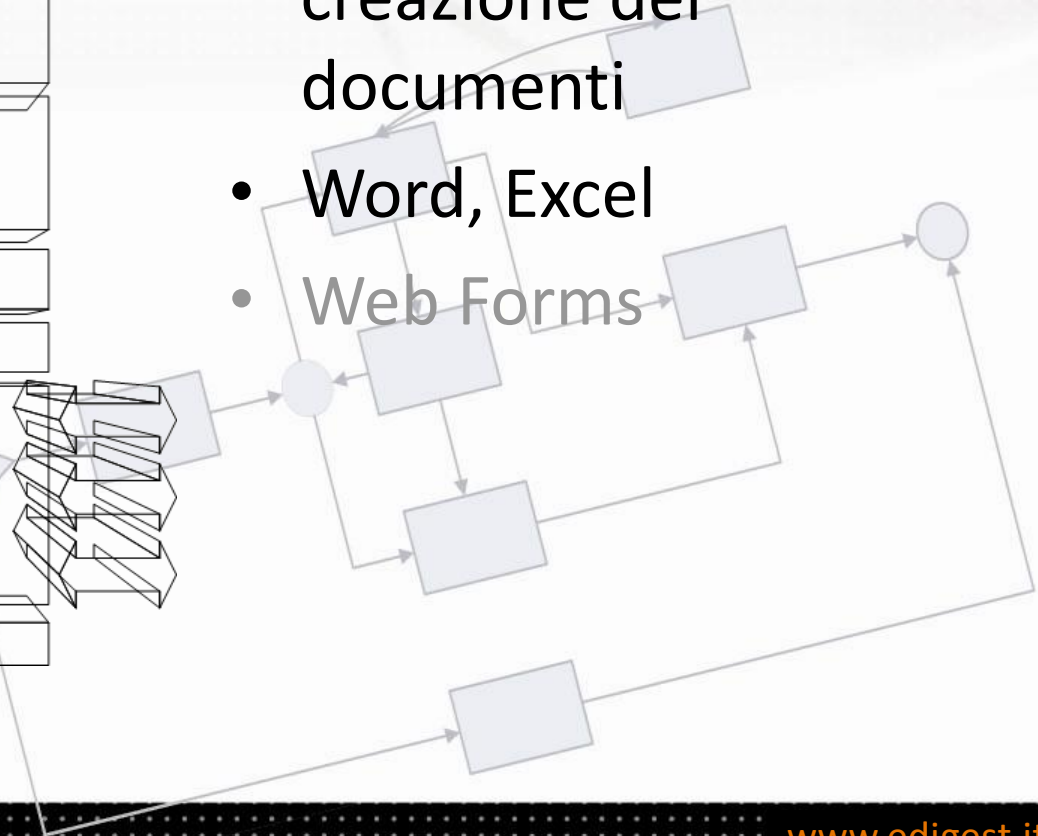

Tipo dati

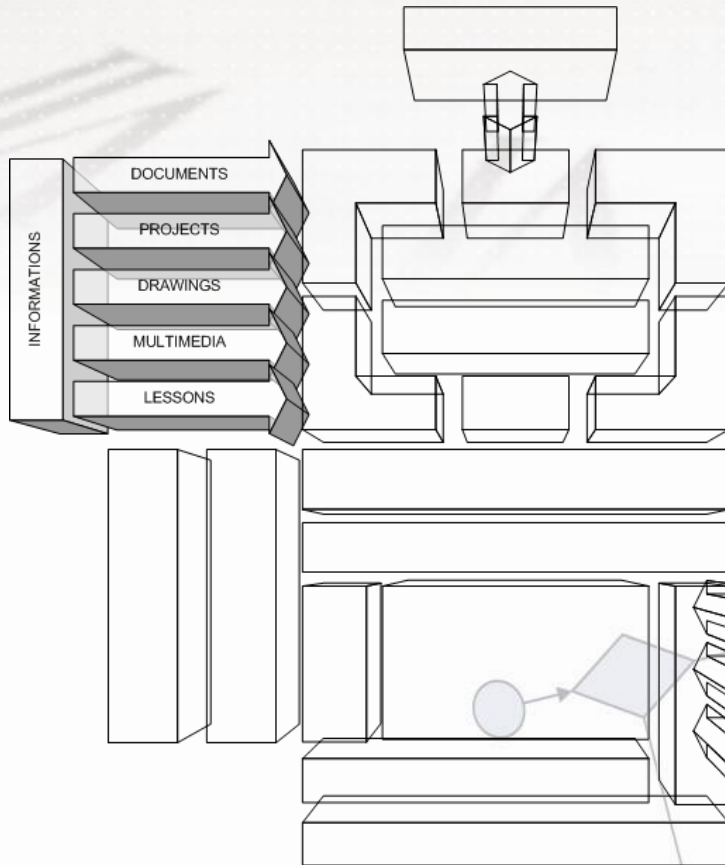

- Possiamo salvare qualsiasi tipo di documenti
 - Documenti office
 - CAD
 - Disegni
 - Musica e Video

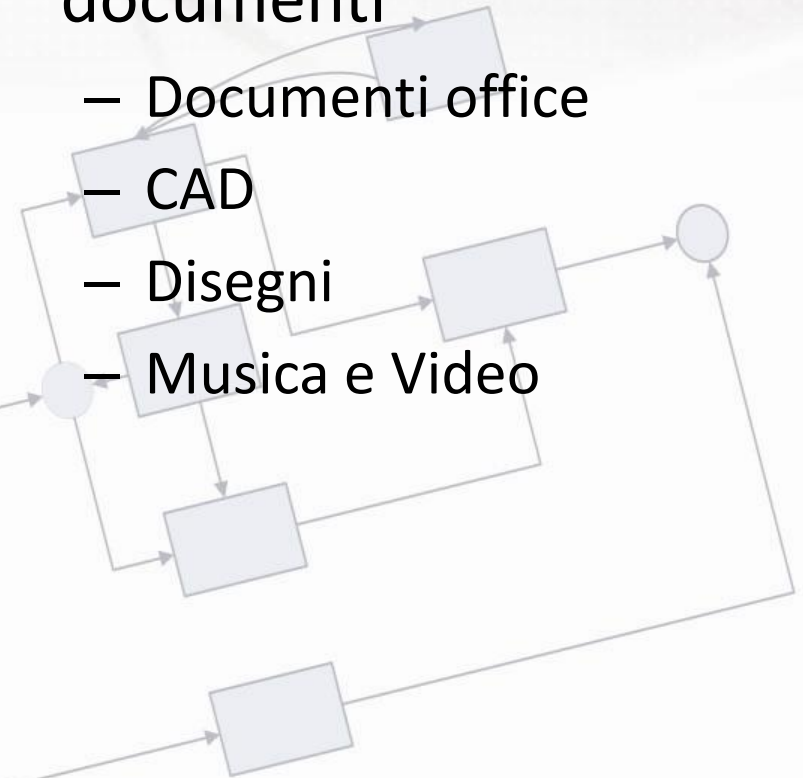

KMS & CMS

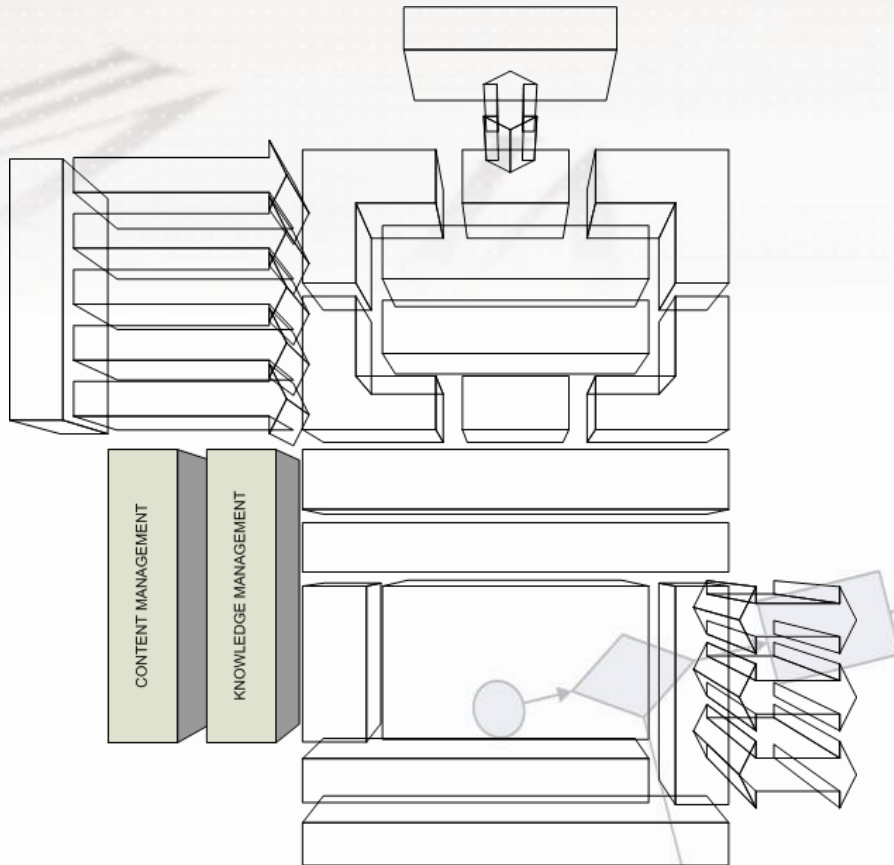

- ARXivar si comporta come un sistema di Knowledge Management quando dovete trovare un informazione
- Può essere integrato con i vostri CMS attraverso l'esposizione di Web Services

An easy way to manage information

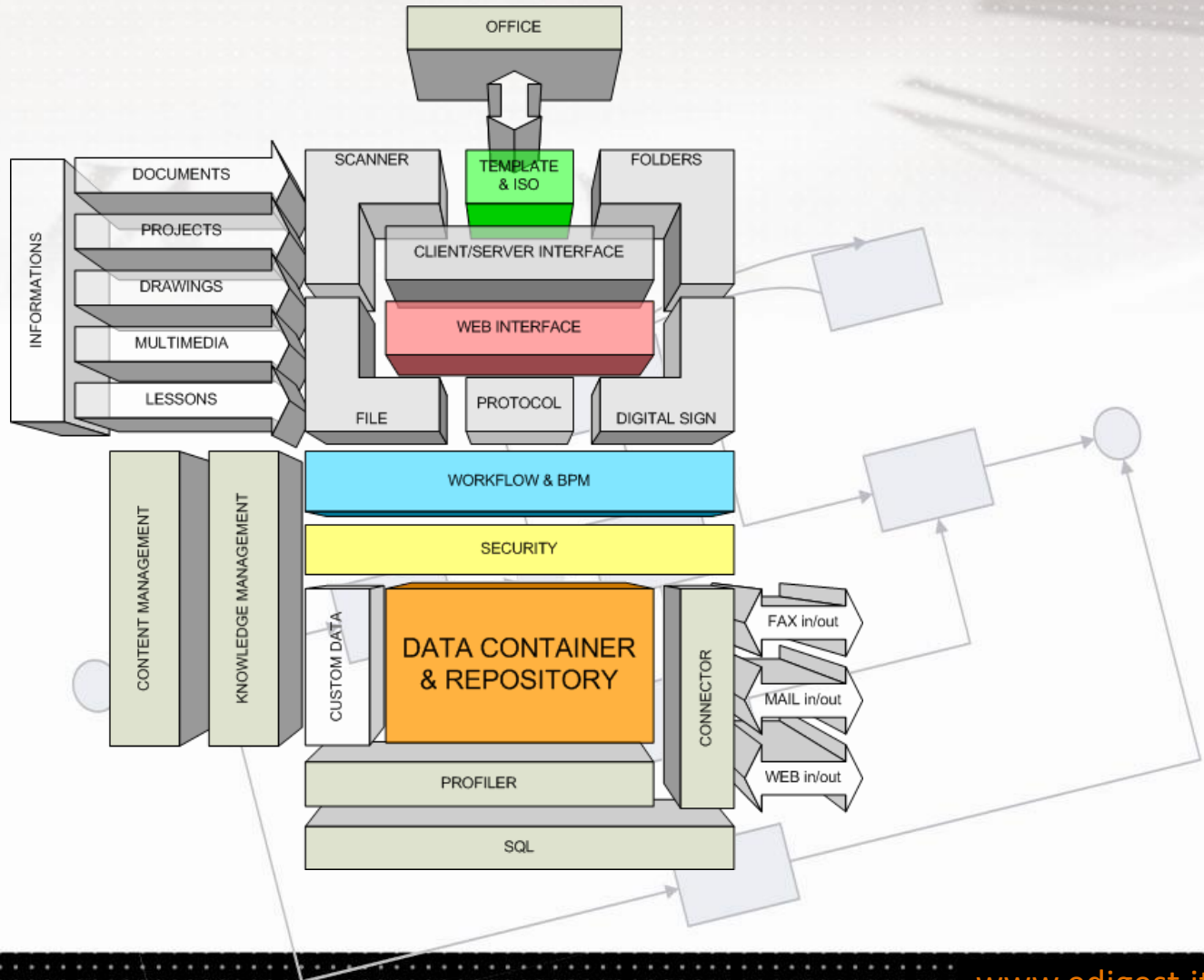

The screenshot displays the ARXivar software interface. On the left, a sidebar contains a 'Commands' menu with options like 'Open', 'Profile', 'Log', 'Delete document', 'Menu list', 'Export', 'Print', 'Versions list', 'Revisa', 'Organize', 'Distribution', 'Full text', 'Barcode', 'Workflow', 'Digital sign', 'Paperless archive', and 'Other operat.'. The main window is divided into several sections:

- Search results table:** A table with columns: Line, System ID, Version, From, To, Document date, Document type. It lists various documents with IDs like DEMO 52, 51, 50, 49, 48, 47, 46, 45, 44, 43, 42, 41, 40, 39, 38, 37, 36, 35, 34, 33.
- Workflow diagram:** A flowchart titled 'Payment approval' showing steps: Start -> Proc -> Knowledge -> Approve -> Invoice payment. It includes decision points for 'Refuse' and 'Approve'.
- Document preview:** A preview of a document titled 'Gartner Magic Quadrant for Suites' with a publication date of 18 February. The text below the title reads: 'Jensilo B. Hill, Michele Cantarini, Gartner has revised its BPMs for the 100 major software...

USO di ARXivar

Xché

- *Ciclo Attivo*
- *Spool Recognition*
- *Ciclo Passivo*
- *Barcode*
- *Conservazione sostitutiva*

- Sicurezza dati
- Condivisione
- Versioning
- Protocollo
- Modelli aziendali
- Integrazione mail / fax

- Approvazione fatture fornitori
- Emissione offerte
- Gestione Qualità
- Approvazioni fidi

Dematerializzazione



Gestione informazioni



Business Process Management



DEMATERIALIZAZIONE

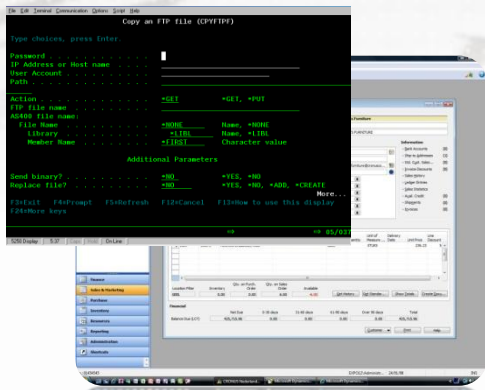

Stampa fattura



Riconoscimento PDF

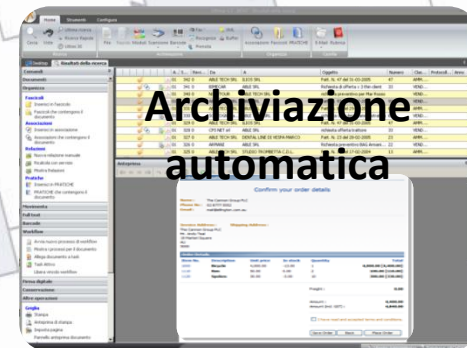

- **CICLO ATTIVO**

- Acquisizione **automatica** dell'output di qualsiasi sistema gestionale

DEMATERIALIZAZIONE

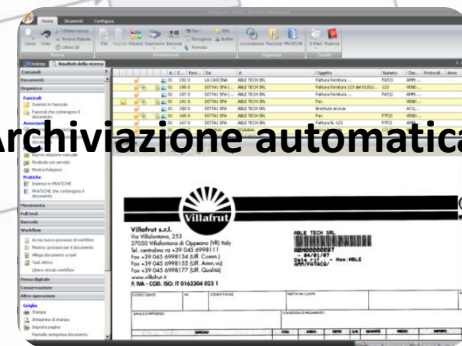
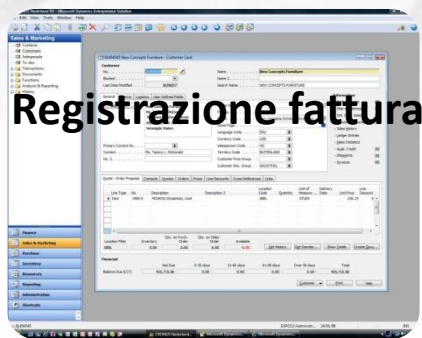

- **CICLO PASSIVO**

- Aquisizione **automatica** attraverso la tecnica dei **barcode** delle fatture fornitori

INTEGRAZIONE FAX

- Integrandoci ai più noti programmi possiamo ricevere ed inviare i FAX direttamente da **ARXivar**

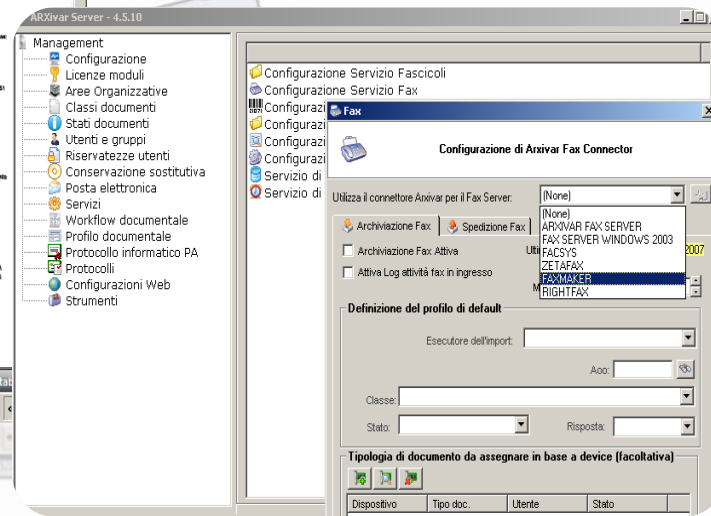
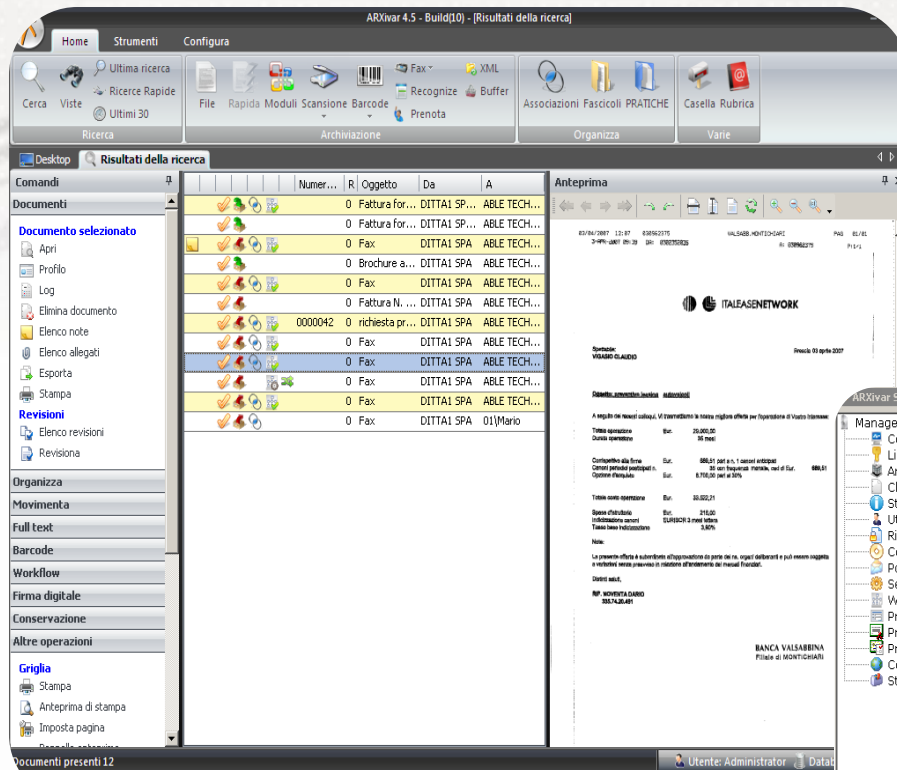

ALCUNI ESEMPI DI FLUSSI

esempio r.d.a.

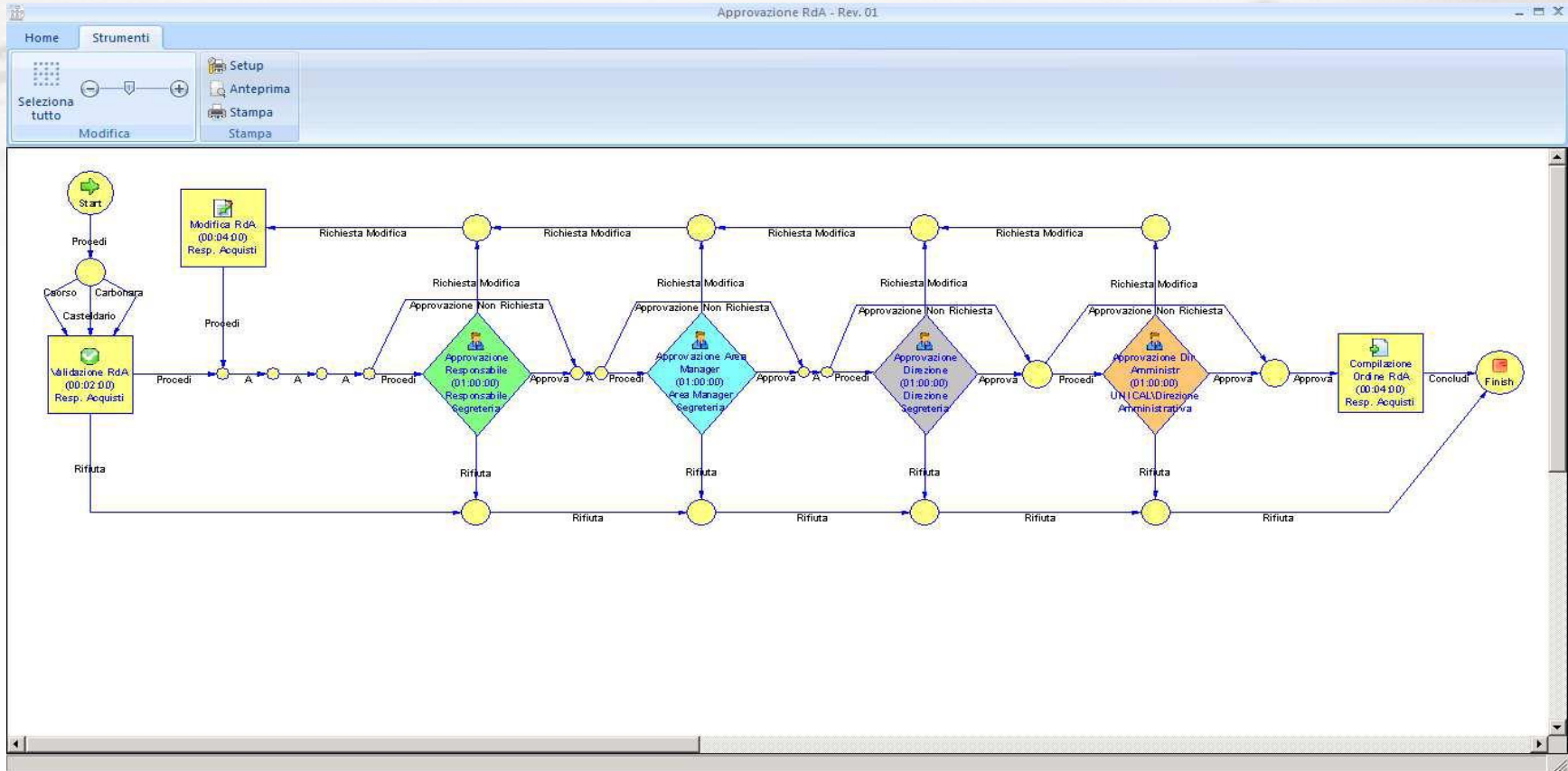

Controllo qualità DDT ingresso

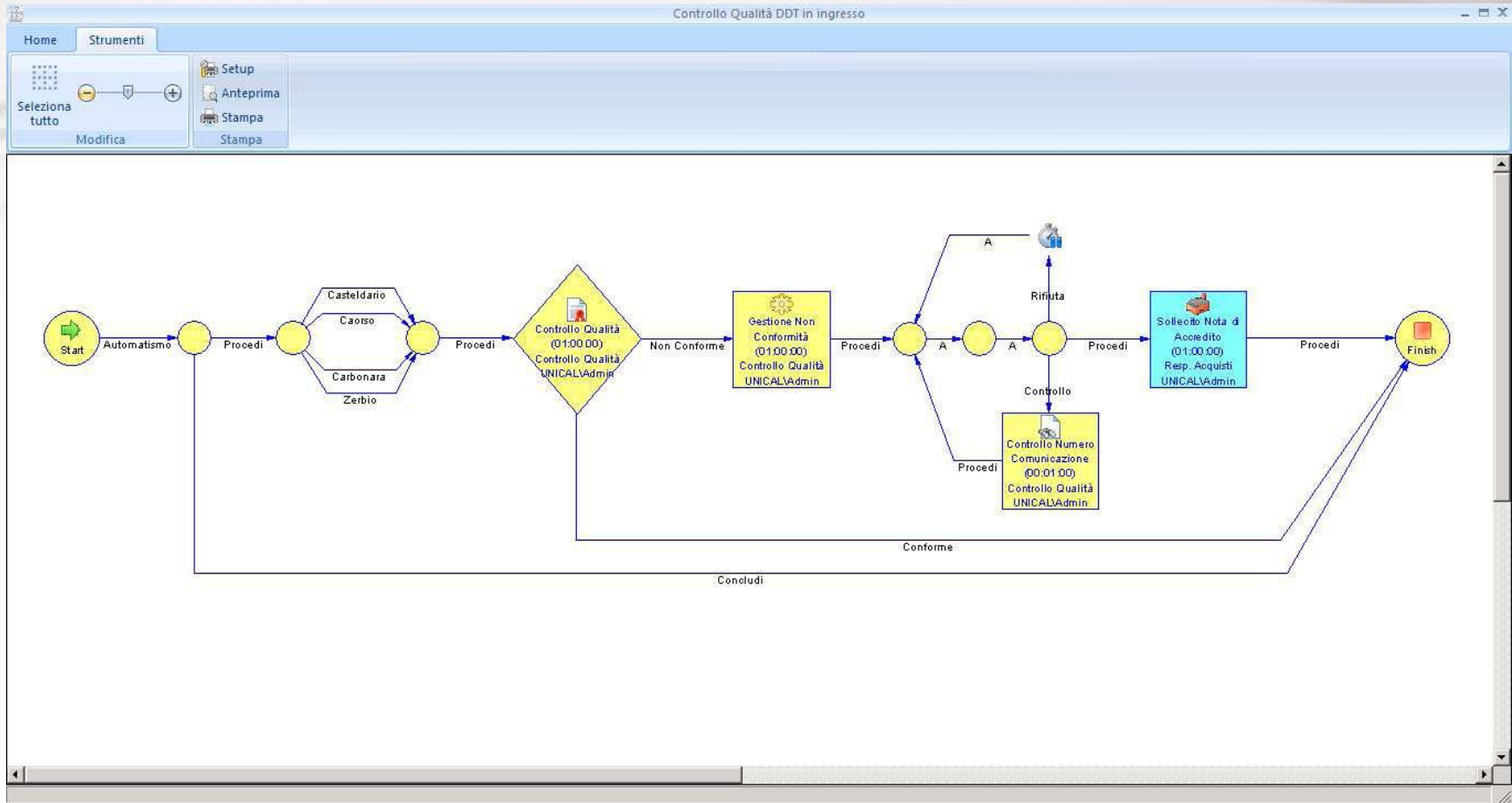

Controllo solvibilità cliente

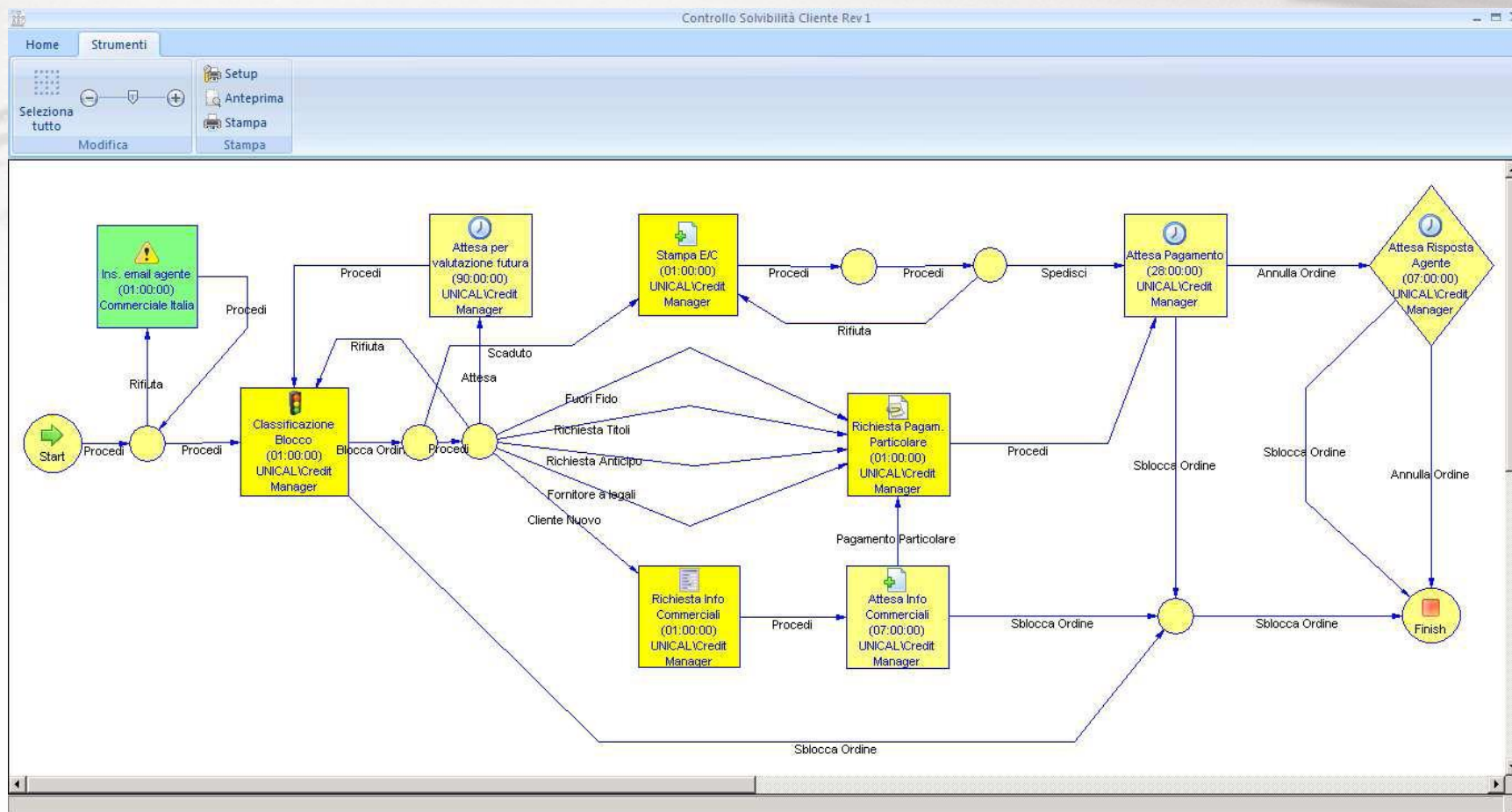

Gestione richieste offerte cliente

